

HKC



XPLORER **2.3** FAMILY **OWNER'S MANUAL**

WWW.HARDKORRCAMPERS.COM.AU

CONGRATULATIONS ON PURCHASING YOUR VERY OWN **HARDKORR CAMPER!**

In doing so, you now have the assurance and peace of mind that comes from purchasing a product that has been manufactured to the highest quality standards.

We hope you will enjoy using this product for many years to come.

If you require technical support, or in the unlikely event your purchase appears to be faulty, please contact our support team for immediate assistance.

- THE HKC TEAM

IMPORTANT, RETAIN FOR FUTURE REFERENCE: READ CAREFULLY

While caution has been taken to ensure the accuracy of the contents of this guide, Hardkorr Campers assumes no responsibility for errors or omissions. Please note that specifications and product functionality may change without notice.

For assistance with assembly or installation, parts and service, visit www.hardkorrcampers.com.au or contact customer service through the following:

✉ enquiries@hardkorrcampers.com.au

PRODUCT USAGE & MAINTENANCE

The aim of this manual is to aid owners in the proper utilization and operation of the Hardkorr Campers Xplorer 2.3F Camper trailer model. The content presented in this manual is directed towards individuals possessing a basic understanding of mechanical and technological concepts. If you lack the requisite skills or access to suitable tools to execute specific tasks, **we recommend seeking professional guidance.**

CONTENTS

Welcome i		Maintenance	
Congratulatory & Support Information		General Care	15
Introduction ii		Water Tank Isolation	16
Purpose of this Manual		Using a Jack Under the Camper Trailer	17
Specifications 1		Adjusting the Handbrake	18
Dimensions & Weights		Dust-Proofing the Camper Trailer	19
Tyres & Axle Information		Trailer Plug Wiring	20
Key Features		Technical Information	
Camper Trailer Walkthrough 3		Connection Terminology	21
Getting Started 5		Control Panel Functions	22
Pre-Trip Inspection	5	Power & Isolation Switches	23
Weight Information	6	Using 240V Mains Power	24
Loading Your Trailer	7	Inverter Package & Wiring	25
Driving Tips (On-Road & Off-Road)	8	240V Inlet Package & Wiring	26
Setting Up Camp		DC-DC Charger & Battery Monitor	27
Choosing a Spot & Levelling	9	Lithium Battery & Accessories	28
Rooftop Tent Setup	10	Warranty	
Inverter & Induction Cooktop	11	Warranty Coverage	29
Tropical Roof Setup	12	Warranty Process	30
Awning Wall Setup	13	Exclusions & Limitations	31
Hot Water System Setup	14	Maintenance Schedule	32

LENGTH	4.45m <i>(from extended draw-bar to rear spare tyre/s)</i>
WIDTH	2.05m <i>(including packed awning and shower ensuite fitted)</i>
HEIGHT	2.3m
GROUND CLEARANCE	0.50m <i>(to water tank)</i>
WHEEL TRACK	1.64m
DEPARTURE ANGLE	25.3°
RAMP OVER ANGLE	59°
TARE WEIGHT	1,470kg
ATM	2,200kg
GTM	2,110kg
AXLE GROUP RATING	2200
BALL WEIGHT	90-160kg depending on set up
PAYLOAD	730kg
TRAILER STORAGE CAPACITY	~3,900L
WATER	170L (100L front tank + 70L rear)
JERRY CANS	2x 20L cans
GAS	1x standard 9kg cylinder holder

TYRES	265/75 R16 MT (31.6")
LOAD RATING	123/120Q
SPEED RATING	160km/h
COLD INFLATION	550kPa
ELECTRIC BRAKE SIZE	12"

12" AXLE DIAGRAM

1	BEARING CAP
2	M5 X 50MM SPLIT PIN
3	CROWN NUT
4	BEARING SEAL
5	1 X SET 43 BEARING – 15123 CONE & 15245 CUP
6	HUB DRUM
7	1 X BEARING – 25580 CONE & 25520 CUP
8	1 x Standard seal 1.937 x 3.375 x 0.500
9	SPRING WASHER & NUT

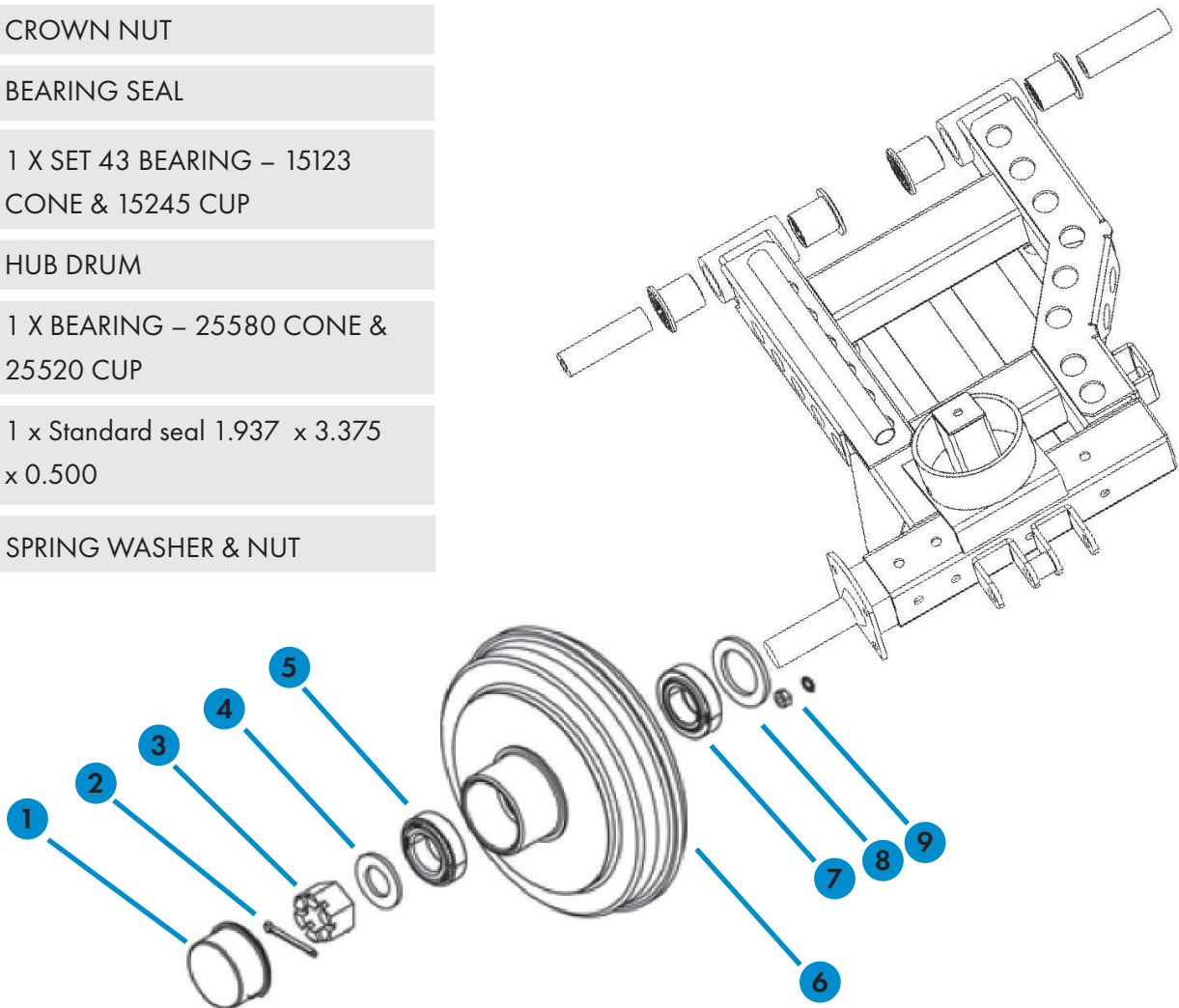

XPLORER 2.3F



1

Hardkorr Electric Opening Double Rooftop Tent

The electric opening and air inflating system is designed for fast, one-person setup. Once all four stabilizer legs are lowered, simply release the latches and press the opening button. The shell will automatically fold open. Attach the included ram guard, secure the two stabilizer poles, and unclip the canvas fastening straps. Then, press the second button and watch as the tent inflates. Finally, attach the included poles to support the window rain flaps, secure the gutter system, and you're ready to go.

2

Tent entry cover

3

Hardkorr XL 270° Free-standing Awning

With a wind rating of 30 KPH without leg poles, you can be sure this awning will survive our tough Australian conditions whether you're at the beach or out in the country. If the weather starts to change, we recommend securing the awning as you never know what Mother Nature is capable of.

4

Hardkorr Fold-Out Hot/Cold Shower Tent

Our Shower Tent is ideal for those looking for a bit of extra luxury while out on the road. Useful as both a shower room and as a toilet or changing space, it can be adjusted in size so that it suits the height of your trailer perfectly. The tent comes with everything you need to get it setup, as well as a removable floor with drain, and a velcro roof piece.

5	Patented integrated stairway entry to rooftop tent With the Xplorer, the game has totally changed. It's the only camper trailer in the world to feature a staircase integrated into the trailer itself, making it much safer and less strenuous to access your tent, regardless of your age or physical condition.
6	Stairway storage compartments
7	Removable stairs
8	Gas cylinder and Jerry can storage
9	Stabiliser legs
10	Pull-out camp kitchen A kitchen sink, Induction cooktop, utensil drawer, and a large prep-bench—everything you need to cook up a storm.
11	Heavy duty independent suspension with big-bore gas shock absorbers
12	Electrical control panel
13	Pull-out fridge slide
14	Door-mounted dual-colour LED overhead lighting
15	Rooftop tent controls
16	240v and 50a outlets
17	Air compressor

PRE-TRIP INSPECTION - CHECK THOROUGHLY

WHEELS

- Correct tyre pressure (35-45psi)
- Tyres are in good condition
- Tread is of legal depth (1.6mm minimum)
- Wheel nuts tight (100-110ft/lb)

HITCHES & CHAINS

- Ensure hitch functions properly
- No damage to the hitch or chains
- Hitch properly lubricated
- Hitch articulates correctly

BRAKES

- Electric brakes function correctly via pedal pressure inside the vehicle
- Breakaway wire connected

TRAILER LIGHTS

- Indicators function properly
- Front marker lamps function properly (turn headlights on)

ELECTRICAL

- Batteries are full and in good condition (Lithium 14v)
- You can see via the monitor your DC-DC is charging your batteries, check solar and vehicle individually.
- Fridge turns on and stays cool (make sure to put some items inside)

UNDER TRAILER

- On each bolt, nut or fitting there will be a paint pen mark, we do this as a precautionary so you can quickly check if anything has come loose in your travels.
- Bearings should be checked prior to departure.
- There are 4x Grease nipples on the control arms, depending on the age or kms of the trailer this should be checked also.

MISCELLANEOUS

- Keys for the trailer doors.
- Tools
- Jack (not supplied by HKC)
- Spare wheel is inflated

WEIGHT INFORMATION

Towing your camper trailer safely under varying conditions can present challenges. Properly loading your camping trailer in a safe and suitable manner can help reduce the risk of potential hazards during your journey. While there may be numerous abbreviations and terms that initially seem confusing, understanding them will ultimately enhance your towing experience.

BALL WEIGHT

This is the downward load exerted on the towing point of your vehicle by the trailer. A general rule of thumb is the ball weight should be close to 10% of the trailers ATM.

TARE WEIGHT

Tare Weight is the total weight of the trailer with all the options fitted by Hardkorr Campers with no liquids or fluids not essential to the operation of the Xplorer camper trailer.

GTM

The gross trailer mass (GTM) is the maximum amount of weight that can be supported by the suspension minus the ball weight.

ATM

The aggregate trailer mass (ATM) is the maximum amount of weight that can be supported by the trailer and **must not be exceeded**.

The Xplorer 2.3F has a Tare Weight (dry) of 1,470kg and an ATM (Aggregate Trailer Mass) of 2,200kg. This gives you a maximum payload capacity of approximately 730kg. After filling the 170L water tank (which adds around 170kg), your remaining allowable payload is approximately 560kg.

You may have also heard about GCM (Gross Combined Mass). This is the maximum allowed mass of the vehicle and trailer as determined by the vehicle manufacturer.

LOADING YOUR TRAILER

To ensure the trailer can be towed safely and effectively, it is recommended to follow the below diagram when packing your Xplorer camper trailer. Adhering to the appropriate weight distribution is crucial to a smooth, safe towing experience.



LIGHTWEIGHT ITEMS

- Clothing
- Food
- Recreational items

MID-WEIGHT ITEMS

- Aluminium frame camp chairs
- Cooking utensils/pots/pans

HEAVY ITEMS

- Trestle table
- Steel frame camp chairs

DANGER

Exceeding manufacturer weight and combination limits can result in loss of control leading to death or serious injury. Your tow vehicle and hitch must be rated for the Gross Vehicle Weight of the trailer.

OFF-ROAD DRIVING

When towing your camper off-road, it introduces a plethora of additional responsibilities and considerations for the driver. When journeying into remote areas, it's imperative to be equipped with an ample supply of spare parts and provisions to handle any unforeseen circumstances effectively.

Prioritise regular preventative maintenance and conduct thorough **daily inspections** without fail.

Essential trailer spare parts should include:

- Wheel bearings (*see page 2*)
- Seals
- Wheel studs and nuts

CORRUGATIONS AND ROUGH ROADS

Corrugated roads pose one of the most challenging and detrimental conditions for vehicles. The continuous vibration experienced can gradually loosen vehicle components, significantly stressing both vehicles and drivers beyond the usual strains of regular road driving. It is essential to take frequent breaks in such conditions to alleviate driver fatigue and prevent excessive wear on vehicles.

The intense heat generated on corrugated roads can pose a risk to shock absorbers, potentially damaging seals and leading to shock absorber fade, where damping effectiveness decreases, and in severe cases, seal failure. To mitigate these risks, it is crucial to adjust tire pressures on both the car and trailer, softening the impact and expanding the tire's contact area with the road surface, particularly on rough and corrugated terrain.

BULLDUST

This occurrence is frequently encountered on outback roads, where fine dust can accumulate in sizable potholes, concealing them from drivers who may not anticipate their presence. It is crucial to decrease speed in such conditions and exercise caution while driving to minimize the risk of damage or accidents. Remember to check and clean vent filters as needed.

SAND

When navigating sandy terrain, it's essential to adjust the tyre pressures on both the vehicle and trailer. This adjustment increases the tyre's footprint, minimising the depth of sinking into the sand.

Always bear in mind that lower tire pressure necessitates lower driving speeds. When reducing pressures to 20 psi or below, there's an increased risk of the tire's bead rolling off the rim, particularly during sharp turns.

CHOOSING A SPOT

There's no such thing as a perfectly flat piece of ground out in the bush, but your camper has stabiliser legs which can help with this. Choose a spot that doesn't have overhanging tree branches where birds and bats nest. Bat poo, especially, can be quite harsh on paint surfaces!

It's also worth noting that Gumtrees, in particular, have a bad history of shedding branches and damaging cars. Be wary of this!

LEVELLING THE CAMPER

On your camper is 4 stabiliser legs, please note these are for stabilising the camper and not raising it. The best way of levelling your camper is to bring some levelling blocks, pieces of timber or anything you can drive the camper onto.

SITE POWER (OPTIONAL)

On the back of the Xplorer will be a black 240V 15A inlet. Using a 15A power lead connected to mains power, insert it into the inlet. From here, the power flows to an RCD before reaching an outlet.

SECURING YOUR CAMPER TRAILER

Something unfortunately not a lot of people consider is bringing a hitch lock and/or a wheel clamp. We recommend having these accessories so you don't have to worry about leaving your camper behind at the site when going on a day trip!



HOW TO VIDEO
PLAYLIST



SETTING UP THE ROOFTOP TENT

The rooftop tent is equipped with an electric opening and air-inflating system for fast, one-person setup. However, safe operation is absolutely critical.

**WATCH OUR
HOW-TO VIDEO**

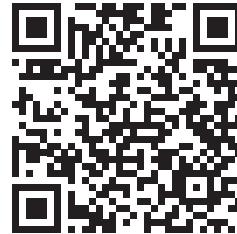

SAFETY WARNING - READ BEFORE SETUP

You must begin by fully lowering all four stabilizer legs. This step is non-negotiable—it ensures the trailer is stable and prevents tipping or collapse during deployment.

Equally important, the two support poles must be installed before inflating the tent. Failure to use these poles can cause severe structural damage to both the rooftop tent and the trailer, and may pose a serious safety risk to the user.

Never attempt to open or inflate the tent without first securing both the stabilizer legs and the support poles.



1 Lower all four stabilizer legs.



2 Release the latches and hold the tent lift button



3 Secure the two support poles.



4 Attach the included ram guard.



5 Unclip the canvas fastening straps.



6 Press the second button to begin tent inflation.

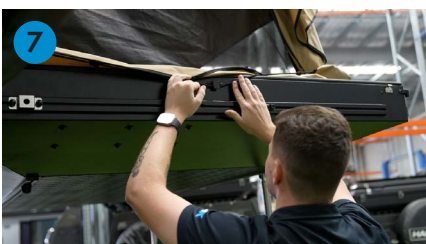

7 Secure the gutter system.



8 Attach the included poles to support the window rain flaps.



9 You're all done!

INDUCTION COOKING AND KITCHEN SLIDE

The 2.3F comes equipped with a 3000W inverter and a 2800W induction cooktop, providing ample power for efficient, off-grid cooking and supporting a wide range of household appliances.



- | | |
|---|---|
| 1 | Power ON-OFF Switch |
| 2 | 12v Cig, USB Power, light switch for illuminating logo |
| 3 | Utensil drawer |
| 4 | Induction hot plate |
| 5 | Tap and Collapsible sink |
| 6 | Dual 240v outlet powered from inverter to power any of your 240v appliances |
| 7 | Controller for 3000W inverter |

HOW TO TURN ON THE INVERTER

1. First hold the power button for 4 seconds on the remote inverter controller located under the control panel box. (This will only switch on if the red power switch on the inverter is switched on)
2. Turn the big power switch on, located on the kitchen slide.
3. You're all set, now power will be sent to both the Induction hot plate and the dual 240v outlet.

IMPORTANT NOTES

Power to the hotplate is automatically switched off when the kitchen slide is retracted. However, we strongly recommend also turning off the main power switch located on the kitchen slide for added safety.

When storing the trailer, we advise switching off the inverter using the red switch on the unit.

Please note: This hotplate has a maximum power draw of 2800W when both plates are on at full power. This is near the limit of the 3000W inverter. If other appliances are plugged in or charging at the same time, the inverter may trip due to overload.

TROPICAL ROOF SETUP

In the camper will be a black bag which contains;

- 1x pieces of canvas
- Pole
- Guide ropes

SET UP

1. Ensure the camper is properly set up, including the awning.
2. At the front entrance of the rooftop tent, secure the tropical roof to the entry awning using the Zip.
3. Using the 2 gold tension poles carefully put them through both eyelets at the tent entrance.
4. Set up 2 extendable poles on the first 2 eyelets and tie down with included white ropes



All done! Make adjustments where needed but that's all you have to do.

The awning is designed to reduce water exposure on the stairs and help keep you dry. However, it is not fully waterproof, and some water ingress may occur along the 270-degree awning side.

AWNING WALL SETUP

Depending on which walls you have, you will need the following;

- Awning wall
- Ground pegs
- Hammer
- Awning pole

SET UP

1. Install a pole to each awning arm where to help support the weight of the canvas as it hangs.
2. With the awning fully setup, attach it the awning wall to the awning edge using the velcro strips at the top of the awning walls.
3. Pull the awning wall out at an angle and secure it to the ground using ground pegs. You may need your hammer for this.

All done! Make adjustments where needed, but that's all you have to do.



Keeping the Velcro clean will ensure its longevity.



HOT WATER SYSTEM SETUP

- If you have purchased a hot water system with your Xplorer the unit will have come with premade hoses. In this kit there will be;
- Freestanding tripod
- Water T-Piece
- Green garden hose with hydraulic fitting
- Braided hose with hydraulic fitting
- Gas connector
- Batteries

SET UP

1. Set up the free-standing tripod, and then hang the hot water system on the stand
2. On the bottom of the hot water system there is two inlets and one outlet. Left side is **Gas IN**, Middle is **Water Out** and the Right side is **Water IN**. Using the provided gas lead, connect the gas lead to the left side of the unit, and connect the other side of the gas hose into the gas bottle.
3. With the green garden hose, connect the hydraulic fitting into the driver's side **TOP** water fitting on the draw bar, and the other side of the garden hose to the **Water IN** connection on the hot water unit. All you need to do now is connect the water outlet. We have designed this in a way where you can have water to the kitchen sink and to the shower head at the same time.
4. Now connect the braided house with hydraulic fitting to the bottom fitting on the drivers side, exactly the same way you did with the garden hose.
5. Now using the third supplied braided hose with a hydraulic fitting, connect to the point on the rear of the trailer to use as a shower house into the tent.
6. Turn the water pump on in the camper.
7. Turn the gas bottle valve open.
8. Turn on the hot water system.

For further information or troubleshooting advice, please contact Country Comfort.

CANVAS

When packing up your tent and awning, it's important to ensure they are clean and dry. Mould is extremely difficult to remove once it has set into the canvas, so spending a few minutes in the sun or wiping down with a towel or dry rag can make a big difference. If you encounter a leak in the canvas, use Seam Sealer to fix the issue. We also recommend placing a moisture absorber or container inside your packed tent to help remove any residual moisture and prevent mould growth during storage.

ZIPPERS (TENT/AWNING)

Never force a zipper - if it jams or binds up, pull it back a few inches and try again. We recommend keeping a can of **dry lubricant** handy in case the zippers become an issue.

CAMPER EXTERIOR

Just like your car, your camper should be taken care of just the same. The exterior is a hammer-tone electric plated finish so you don't have to be as careful with it, but for longevity basic soap wash and occasional buff/wax will keep your camper in great condition.

CAMPER INTERIOR

High humidity environments like North Queensland and cooler climates can create condensation, add some heat to that and you have the perfect environment for mould. For a few dollars at any grocery store, a moisture absorber stored in the tent and body of the camper will ensure no nasty surprises when you take your camper back out on your next holiday. If you are in a cold climate, open the top of the window zippers slightly to stop the condensation from your breath from being trapped inside the tent, if you don't open up some zips, in the morning you will notice moisture inside your tent roof and walls. A fan running through the night will also help prevent moisture in the tent.

CAMPER UNDER-BODY

No doubt at some stage you will want to do a beach camping trip! Even though the body of the camper is aluminium and chassis has been hot dip galvanised ensuring rust proofing, salt has a way of finding any nook or cranny that is unprotected. A couple of minutes spent with a spray can of **lanolin** works wonders, we recommend doing this before and after your trip!

BATTERIES

In contrast to standard batteries, lithium batteries benefit from being discharged as much as possible when stored for extended periods. Doing so can help maintain the condition of your batteries over time. At the conclusion of a trip, consider leaving some lights on in the camper to gradually discharge the battery to around 40% or 13 volts.

ISOLATING WATER TANKS

Under the body of your camper trailer you have two water tanks. The front water tank is 100L and the rear is 70L. In the first door on the drivers side of the trailer, on the opposite side of where your breaker switches are, there are two isolation valves.



The valve on the left, which is closest to the door, is the isolator for the front tank. The valve at the back is the isolator for the back tank.

If the valve is like the photo above, the valve is open. If the valve is like the photo on the right, the valve is in its closed position.

We recommend draining the two tanks together rather than individually. If the water pump starts to make noise once pressure is built or the water is extremely aerated one of the tanks may be empty.

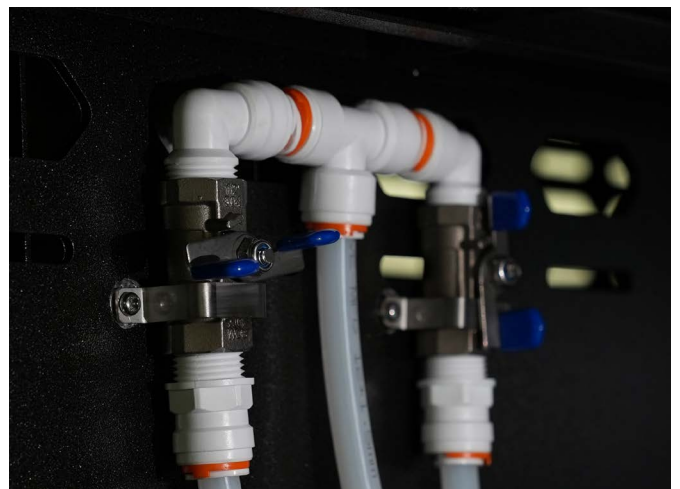

USING A JACK UNDER THE CAMPER TRAILER

The Xplorer has no specific jacking point, but the best jacking point is under the control arm by the shock absorbers. The best and safest method for jacking the camper is as follows

1. Using an appropriate sized jack, raise the trailer up by the control arm near the shock absorbers.
2. When jacking the camper up, have the camper trailer's stabiliser legs being adjusted as you do this to touch the ground. This is not necessary but safety is paramount.
3. Once the camper is at your desired height, before going under the camper please ensure you have adequate safety measures in place, the weight of the camper being supported by the jack, stabiliser legs or both at the same time is not adequate.
4. Where possible depending on the circumstances, be sure to place a wheel, large rock or tree stump under the trailer while its jacked up, or if possible have jack stands on various points of the trailer chassis.



RECOMMENDED JACKING POINT

ADJUSTING THE HANDBRAKE

Naturally as your camper ages your handbrake is going to require adjusting. Loosen off the two 17mm nuts and close the gap between them by rotating the round disc on the bolt, pull the handbrake and check for tension. Once happy tighten the nuts back up.

Please note that you do not want this too tight. If done up too tight you may cause unnecessary wear to the brake pads.

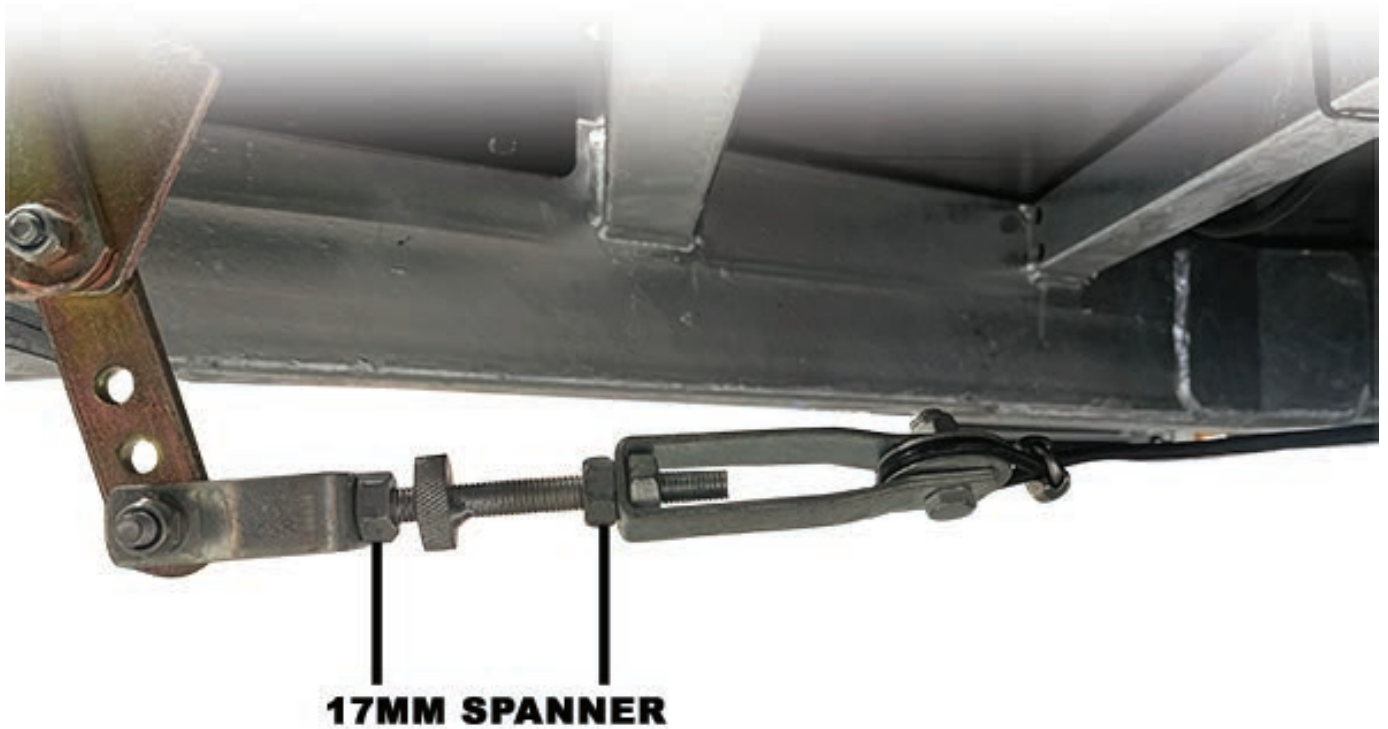

DUST-PROOFING THE CAMPER TRAILER

On each door of the Xplorer there are three door locks which are all adjustable. Using a 10mm spanner, loosen the locking nut. By winding the bolt outwards, this will increase the clamping force of the lock against the body of the trailer which will result in the door rubbers being squished more. There is no set limit as this will be done by feel. Please note leaving the door rubbers set for the entirety of the campers life will reduce the effectiveness of these rubbers, in storage it is best to loosen off the bolts to keep the rubbers plush.



Door Lock



10mm spanner on locking nut

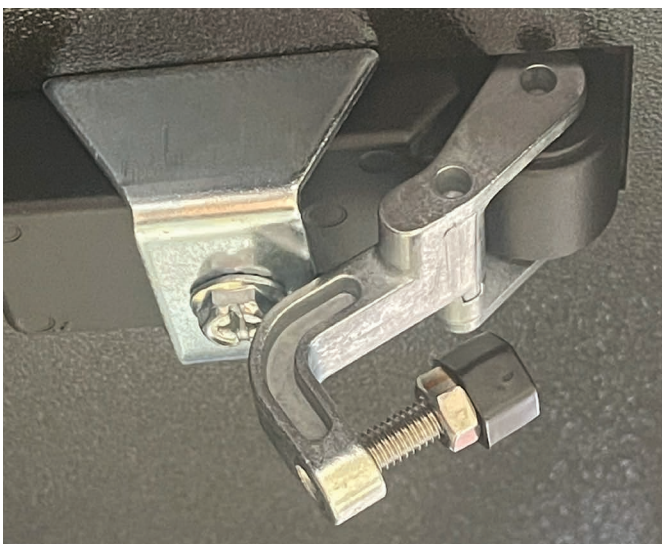

Bolt wound all the way out for maximum pressure

TRAILER PLUG WIRING

The below pin-out diagram can be used to diagnose any faulty connections if one or more lights in the camper trailer are not functioning.

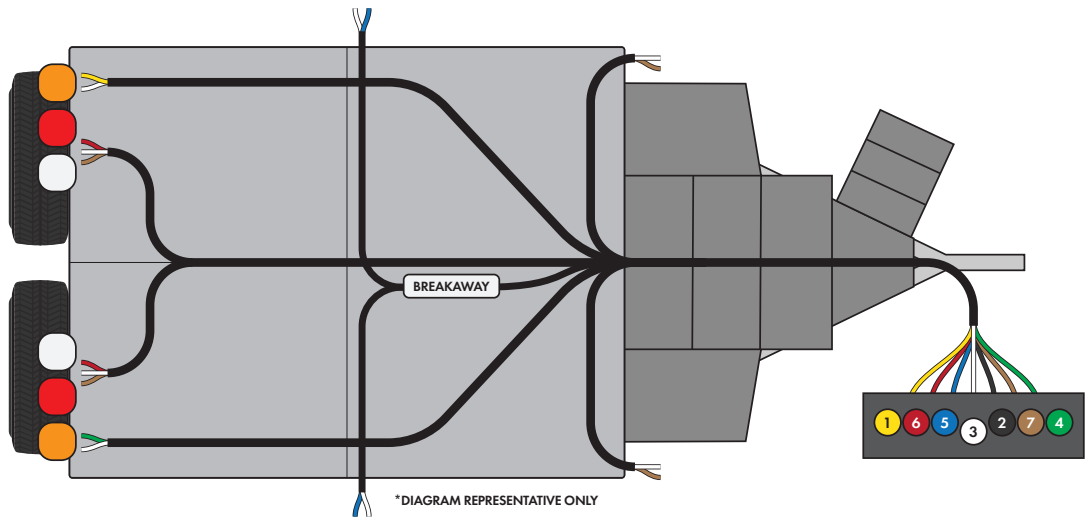

Male plug



1	LEFT indicator	5	Service brakes
2	Reverse lights (not used by HKC)	6	Brake lights
3	Earth	7	Tail lights, side markers, clearance lights
4	RIGHT indicator		

Please note: All lights have been tested before delivery of your camper trailer.

CONNECTION TERMINOLOGY

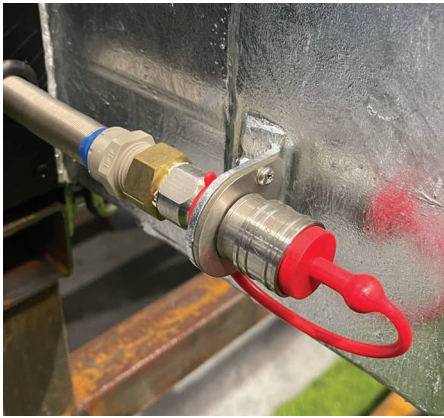

FEMALE WATER CONNECTOR

1/4" ISO-B Hydraulic hose
quick coupler plug.
(stainless steel - ISO 7241-1 B)



MALE WATER CONNECTOR

1/4" ISO-B Hydraulic hose
quick coupler plug.
(stainless steel - ISO 7241-1 B)



SOLAR PANEL INPUT

WS20 2-pin electrical aviation
connector (female).



7-PIN FLAT CAR CONNECTOR

Male 7-pin flat connector for
trailers/caravans.



3-PIN ANDERSON PLUG

3-Pin 50A Anderson-style plug for
DC-DC charging.



240V 15A MAINS INPUT

15A plug connection found
at caravan parks or powered
campsites.

CONTROL PANEL FUNCTIONS



WATCH OUR
VIDEO TUTORIAL



1	Hardkorr Battery Monitor	5	Main Power Isolator
2	USB 2.0, USB 3.0, 12v Cig	6	Water Meters
3	Water pump switch, lighting switches, fan switch	7	Rear Light Switch
4	Reset Switches		

1. The battery monitor will show you everything you need to know regarding the status of your battery. It will display how many amp hours you have left, how long you can last until you're dead flat, and will show you the charging and discharge status in real-time. If you have an inverter, you can also use the display to gauge how many watts you are drawing. For more information, scan the QR Code.
2. USB ports that you can use to charge electronic devices such as phones or tablets. They will have a built-in blue light. When power is supplied, this blue light will turn on. Beside the USB ports is a 12v cig that you can use for 12V accessories.
3. By pressing the Water Pump Switch, it will turn the pump on. The pump will automatically stop drawing power once it builds pressure. It is highly recommended that you do not travel or leave the trailer unattended with the pump switch turned on.

1. You will know the switch is on via the blue LED ring around it. The kitchen light switch simply allows power to flow through to the mini control panel on the pull-out kitchen. The light switch simply allows power to flow through to the lights on each door of the camper. This does not turn your lights on and off. If your lights do not turn on by pressing this switch, you have to manually turn your lights on via the dimmer switch near the light located on the door.
2. These are reset switches, if you ever find there is a fault with the water pump or the fan does not work, try pressing these reset switches.
3. This is the main isolation switch for all the accessories the control panel features.
4. On the left is your 100L water meter. On the right is your 70L water meter.
5. This is your rear light switch that will turn on the rear reverse lights as a flood light.

ISOLATION SWITCHES

Your Xplorer camper is equipped with two key isolation switches for safety and system management:

80A Isolation Switch (Located Behind the Inverter):

This switch is designed to isolate the 12V battery system when performing maintenance or installing additional 12V outlets or devices. Note: The inverter will remain operational even when this switch is turned off.

300A Inverter Isolation Switch (Located Behind the Inverter):

This switch protects the system by cutting power if a load exceeding 300 amps is drawn from the batteries. If this occurs, disconnect any high-draw appliances and reset the switch by turning it back on.

WATER PUMP

Our campers are equipped with a pressure-lock water pump system. To activate the pump, simply press the water pump button on the control panel. If all taps are closed, the pump builds and maintains pressure without running. Once you open a tap, the pump automatically starts to deliver water.

Important: Always switch off the water pump when leaving the trailer. If the pump is left on and a water line is damaged—such as by a rock while traveling—it could result in your fresh water tank draining completely and the pump burning out.

FAN SWITCH

We've mounted a 12v electric fan on the camper door near the kitchen, serving two key purposes: to help keep the interior cool in hot conditions and to reduce dust ingress while traveling. In warmer weather, the fan draws in cooler outside air, circulates it through the camper, and pushes it out through the opposite vent to improve airflow and comfort inside. When driving on dusty roads—such as the bulldust-filled tracks of central Queensland—the fan can also be used to pressurize the camper's interior and help prevent dust from entering. For dust prevention to work effectively, the opposite vent should be sealed to maintain internal pressure.

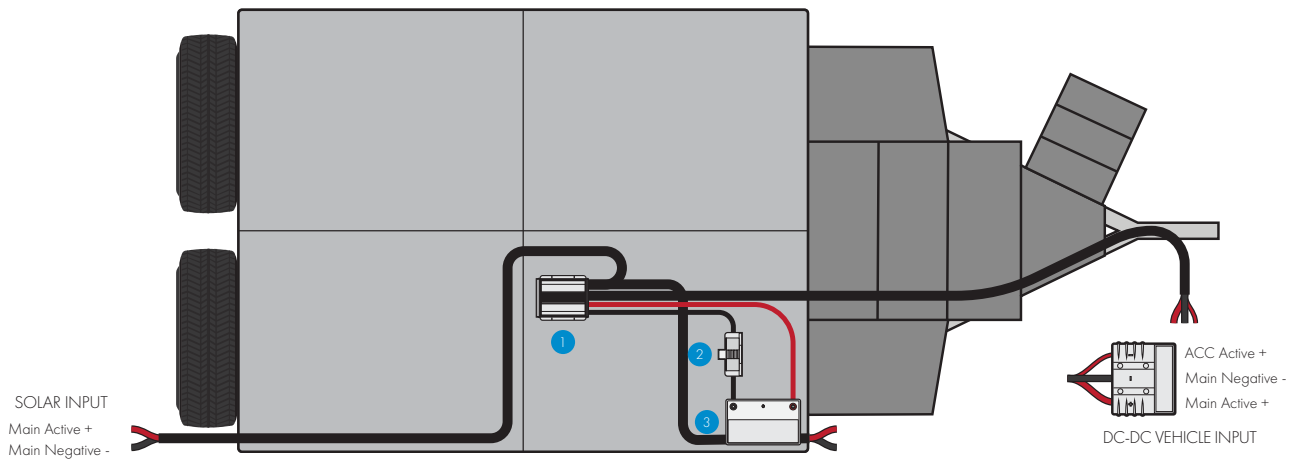

1 DC-DC CHARGER

Serves as both a charging point for the battery via the vehicle's alternator, as well as a regulator for the solar-generated power.

2 SHUNT

Used to measure power coming into and out of the trailer battery system.

3 BATTERY

Power your 12V electrical devices with the power from the battery.

SOLAR INPUT BREAKER: 40A

3 PIN ANDERSON BREAKER: 50A

DCDC OUTPUT BREAKER: 50A

USING 240V MAINS POWER

Connect the 15A power lead to the rear inlet of the trailer. Incoming power will pass through a 15A RCBO circuit protector, then feed a dual 240V outlet located nearby. Note: This outlet is powered by shore power only.

From the RCBO, power also continues to a heavy-duty 25A battery charger, which automatically begins charging the batteries once the camper trailer is connected to a power source.

Additionally, there is a separate dual 240V outlet located under the control panel. This outlet is powered exclusively by the inverter and will only function when the inverter is turned on.

USING THE DC-DC CHARGER

The DC-DC unit installed in your camper serves two primary functions: solar and vehicle charging. What's even more convenient is its automatic feature, which selects between solar and vehicle charging based on the power output. For instance, if you're driving and your solar input is at +10A while your vehicle input is at +15A, the system will prioritize the vehicle input over solar. However, it's important to note that the unit will not combine both inputs to reach a total of +25A. The 2.3F features 2 solar inputs one at the rear and one at the front seen in diagram.

3-PIN ANDERSON-STYLE PLUG WIRING

You will require a 3-pin Anderson to use with your DC-DC Charger. We use a 3-Pin so when you turn your car off, the DC-DC knows to turn off and not drain the battery flat in your vehicle.

INVERTER WIRING DIAGRAM

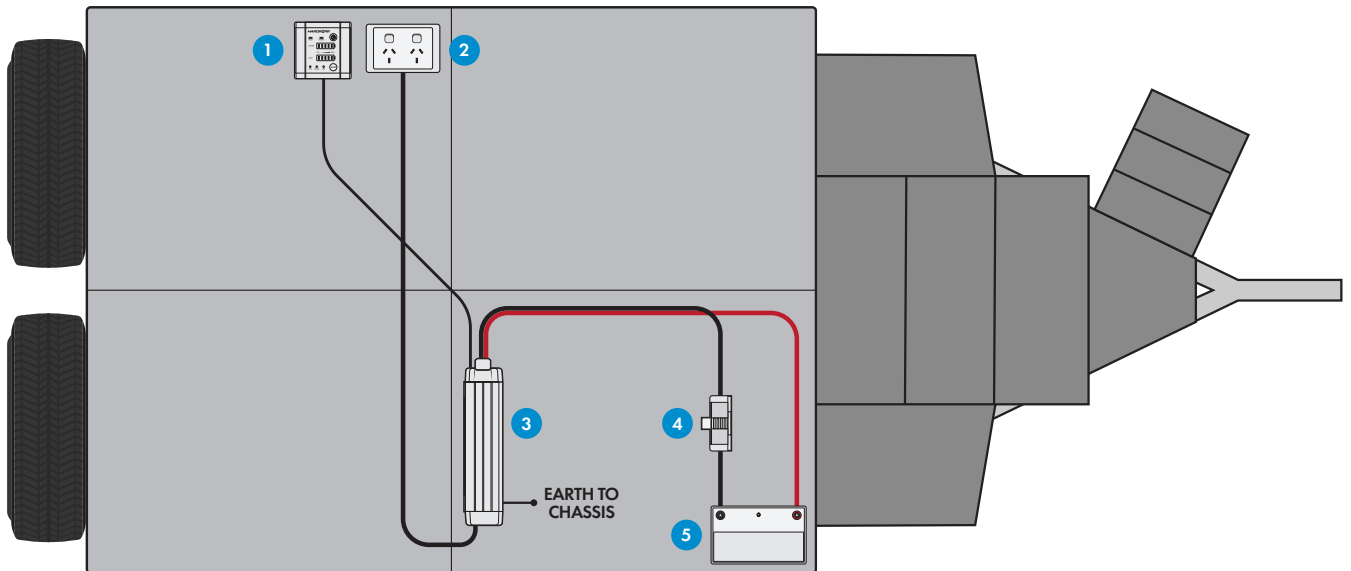

NOTE: THERE WILL BE BREAKERS / FUSES ON THE MAIN POSITIVE CABLE FROM THE INVERTER TO THE BATTERY.

- 1 INVERTER REMOTE**
Used in conjunction with the inverter, often a telephone cable style mounted to the front or rear of the inverter.
- 2 240V WALL OUTLET**
Connect your 240V appliances to power when the inverter is switched on.
- 3 INVERTER**
Used to convert 12V power to 240V power.
- 4 SHUNT**
Used to measure power coming into and out of the trailer battery system.
- 5 BATTERY**
Power your 12V/240V electrical devices with the power from the battery.

240V INLET WIRING DIAGRAM

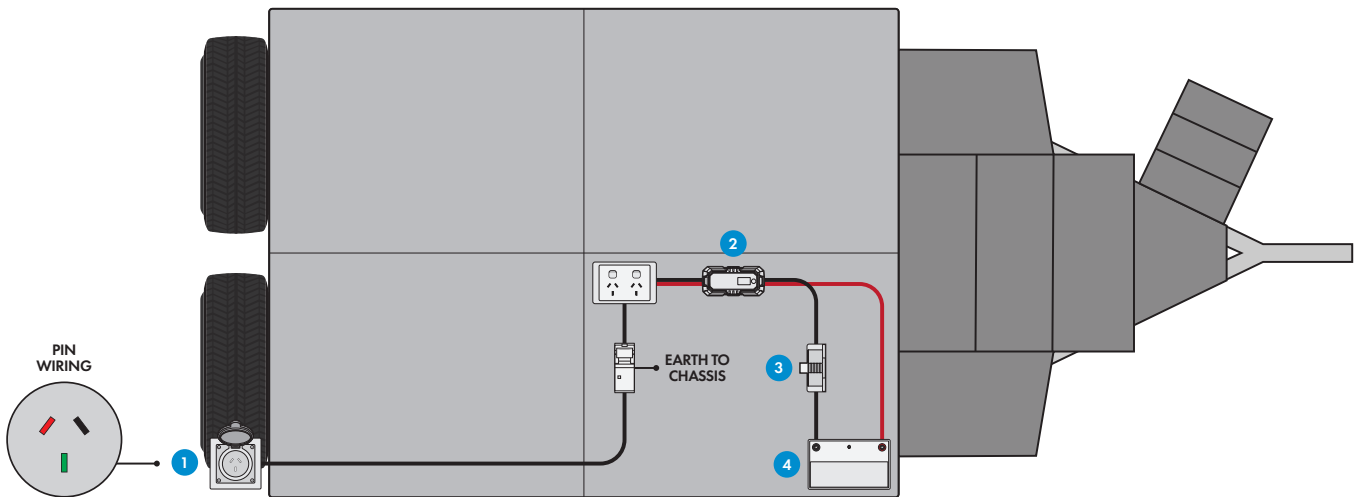

NOTE: THERE WILL BE BREAKERS / FUSES ON THE MAIN POSITIVE CABLE FROM THE CHARGER TO THE BATTERY.

- 1 240V 15A INLET**
Feeds 240V power from mains to the charger via the RCBO/wall outlet.
- 2 AC CHARGER**
Used to charge your battery from mains power.
- 4 SHUNT**
Used to measure power coming into and out of the trailer battery system.
- 5 BATTERY**
Power your 12V electrical devices with the power from the battery.

HARDKORR

We only use Hardkorr branded batteries, solar panels, chargers etc. As technology progresses we are always updating the products we use in our campers. If you cannot find the manual of your charger or battery please visit the Hardkorr website at www.hardkorr.com/au

40A DC-DC CHARGER

We use the Hardkorr DC-DC charger which controls 2 charging functions. Solar and Vehicle. When driving along, your car will be charging your batteries in the trailer or when you're parked up, charging from your solar panels.



BATTERY MONITOR

This battery monitor displays essential information such as battery voltage, live current draw (A) and charge level (Ah and %) through its full-colour LCD screen or by connecting your smartphone via Bluetooth. A=Amps | Ah= Amp Hours



3000W INVERTER

Bring the convenience of your favourite appliances from home with you whether you're touring the country, on a weekend away, or on the job site. Capable of charging your everyday devices or powering appliances like your coffee machine or induction cooktop, our 3000W inverter is perfect for those wanting to work or live out of their 4x4, caravan, or camper trailer.



135AH LITHIUM BATTERY

Our latest range of 135Ah lithium (LiFePO₄) deep-cycle batteries are the most reliable, technologically-advanced batteries we have ever manufactured. With Bluetooth® monitoring, outstanding performance characteristics, full international certification and 135Ah of usable power into a standard Group 27 (N70) size case, you'll never be caught short of 12v power again!



25A BATTERY CHARGER

Charge your batteries from AC/mains power with our 240V Battery Chargers. Equipped with an automatic 9-stage charging system, our chargers are designed to quickly get your batteries up to health. The charger can be used with 12V SLA, AGM, calcium, and LiFePO₄ batteries.



HOW TO VIDEO
PLAYLIST



YOUR WARRANTY

Our warranty is designed to cover genuine manufacturing faults or defects. It's **NOT** a form of insurance, and it doesn't cover damage caused by neglect, lack of care, misuse, or intentional damage. Proper use and regular maintenance are essential to keeping your trailer and accessories in good working order, and issues arising from poor care or improper handling fall outside warranty coverage.

HKC warrants that, subject to the limitations and exclusions below, all parts of our manufacture or assembly of the Camper Trailer are free from defects in material and workmanship for a period of:



12 MONTH WARRANTY	Canvas, electrical components, breakers, plumbing, fuses and wiring
2 YEARS WARRANTY	Body and Suspension
5 YEARS WARRANTY	Chassis
MANUFACTURERS WARRANTY	Hardkorr accessories and other 3rd party items.

All others carry a manufacturer – 12 month warranty unless otherwise stated from the date of purchase. Any shortcomings in the original material or manufacture will be corrected without charge to the original purchaser for parts and labour incurred in that rectification. If work under this warranty is required, the purchaser should immediately contact the selling distributor to make arrangements for the repairs.

All repairs must be approved before works commence in writing. The warranty is not transferable to a subsequent purchaser if the Camper Trailer is sold by the original purchaser during the warranty period. Your HKC comes with guarantees that cannot be excluded under the Australian Consumer Law. The benefits within our Warranty are in addition to other rights and remedies under the Australian Consumer Law in relation to this product.

This warranty is for the benefit of the original purchaser only and is not transferable under any circumstances. It is also voided if the Product is used in hire schemes or as rentals.

IN THE UNLIKELY EVENT THAT YOU ARE STRANDED, WE DO NOT PROVIDE RECOVERY OR ROADSIDE ASSISTANCE. YOU WILL NEED TO TOW YOUR CAMPER TRAILER TO A REPAIR AGENT AT YOUR OWN EXPENSE.

IDENTIFY THE ISSUE

Before initiating any warranty process, carefully assess and document the problem. Make note of:

- Product details (model, serial number, purchase date)
- A description of the issue
- When the problem started and under what conditions

This information will be essential for the next steps.

If the problem you are experiencing is related to a third-party accessory (e.g. a fridge or hot water system), you will need to contact the manufacturer directly. However, if the issue is with the camper trailer itself (e.g. suspension components, tent, or awning) or a Hardkorr electrical accessory (e.g. DCDC charger), you can contact Hardkorr Campers.

CONTACT US FOR SUPPORT/HELP

You must follow the correct process to have your warranty claim resolved. All issues must be reported through our customer support team using the online support portal below. This is the only way to have your claim reviewed and resolved efficiently.

Online Support Portal: hardkorrcampers.com.au/warranty-policy/

LOCATE A SUITABLE REPAIR AGENT

If the issue cannot be resolved remotely, we will assist you in finding a repair agent. We may:

- Recommend authorized repair centers
- Provide you with a list of certified service providers
- Verify if your preferred technician is qualified for the repair under warranty.

Since many of our customers require warranty services while traveling, we strongly recommend that you choose your own repair agent. This allows you to manage the process according to your schedule and travel plans.

SEND QUOTE TO US FOR ACCEPTANCE BEFORE COMMENCING WORK

Once the repair agent has assessed the issue, ensure they provide a detailed quote. This quote should include:

- Breakdown of parts and labor costs
- Estimated time for completion

Send this quote to us for review and approval before any repair work begins. We will notify you of our acceptance or request further clarification if necessary.

HAVE THE ISSUE FIXED

After receiving approval from us, the repair work can proceed. The repair agent will:

- Fix the issue based on the approved quote
- Provide any required documentation, such as repair receipts or reports.

Once the repair is complete, send us a photo of the repair receipt for reimbursement. Ensure that the receipt clearly shows the total cost, date, and repair agent details.

VERIFY THE FIX

After repairs are completed, check that the product is functioning correctly and that the issue has been fully resolved. Keep all documentation for your records in case further follow-up is needed.

For further assistance at any point, feel free to contact our support team.

THIS WARRANTY DOES NOT APPLY IF THE DAMAGE OCCURS BECAUSE OF:

- Accident
- Fair wear & tear; which includes fading and other environmental caused damage.
- Misuse, neglect or abuse, including failure to adhere to servicing and/or maintenance guidelines or exceeding load limits;
- Immersion in water or other use which contravenes our usage guidelines
- Storm damage or other acts of Nature
- Unauthorised modifications or repairs made or attempted
- Continued usage or towing after a defect has, or should have, become apparent to you
- Fitting or installation of any accessories or options such as an altered tool box or other items after the camper trailer has left the premises of HKC.

Should a warranty claim become necessary during the warranty period then the product should be returned to the place of purchase or the nearest HKC authorised dealer at the cost of the purchaser. The warranty covers the original Camper Trailer only. It does not cover the following items:

1. Appliances and equipment which are not manufactured or supplied by HKC (for example a refrigerator, freezer or customer modifications) are covered by the warranty of such items for the term offered by the manufacturer of such items.
2. Any defect resulting from fitting or installation of any accessories or options such as an altered tool box or other items after the camper trailer has left the premises of HKC.
3. Any rectification or other work required due to alterations in Local, State or Federal legislation which occurs after manufacture of the recreation vehicle.
4. Any consequential damages or repair work necessitated due to continued usage or towing after a defect has, or should have, become apparent to the purchaser or user.
5. Any accommodation or re-location expenses including fuel/freight. Loss of earnings or rents or other costs incurred before or whilst repairs under this warranty are being affected.

NOTE: This manufacturer warranty does not cover general consumable parts on the Camper Trailer and rust on any painted surfaces of the trailer or any of its components. (E.g. axles, tires, bearings, springs, couplings and jockey wheels.) HKC is not liable for uneven tire wear, which is not covered under warranty.

TRANSIT

HKC is not liable for any loss, theft, or damage to any goods in transit; however, we are happy to help in resolving shipping issues if reported to us within 12 hours of delivery.

MAINTENANCE SCHEDULE

ITEM / COMPONENT	3 MONTHS / 1,000km	6 MONTHS / 5,000km	12 MONTHS / 10,000km	18 MONTHS / 15,000km	24 MONTHS / 20,000km	30 MONTHS / 25,000km	36 MONTHS / 30,000km	42 MONTHS / 35,000km
BATTERY CONDITION	T	T	T	T	T	T	T	T
BRAKE CABLE	I/A	I/A	I/A/L	I/A	I/A/L	I/A	I/A/L	I/A
HITCH	A	I	I/L/A	I	I/L/A	I	I/T	I
HV POWER SYSTEM	T	I	I/T	I	I/T	I	I/A	I
JOCKEY WHEEL	A	I	I/A	I	I/A	I	I/A	I
LOCKS AND HINGES	I/A	I	I/L/A	I	I/L/A	I	I/T	T
LPG SYSTEM	T	T	I/T	T	I/T	T	I	I
PANEL AND PAINT	I	I	I	I	I	I	I/T	I/T
PLUMBING SYSTEM	T	I/T	I/T	I/T	I/T	I/T	I	I
SEALS AND GROMMETS	I	I	I	I	I	I	I/T	I/T
SIGNALING LIGHTS	I/T	I/T	I/T	I/T	I/T	I/T	I/A	I
STRUCTURAL FIXINGS	A	I	I/A	I	I/A	I	L	L
SUSPENSION BUSHES	I	I	L	I	RCL	I	A	A
SUSPENSION TORQUE	A	A	A	A	A	A	I/A	I/A
TYRE PRESSURE	I/A	I/A	I/A	I/A	I/A	I/A	C	C
VENT FILTER	C	C	C	C	C	C	I/A	I/A
WHEEL ALIGNMENT	I/A	I/A	I/A	I/A	I/A	I/A	RCL	A
WHEEL BEARINGS	A	A	RCL	A	R	A	I/A	I/A
WHEEL NUTS	I/A	I/A	I/A	I/A	I/A	I/A	I/A	I/A

RCL	Remove/clean/lubricate	C	Clean	R	Replace	I	Inspect
L	Lubricate	A	Adjust	T	Test		

Regular use	Extreme (off-road) use



LIFE
WITHOUT
LIMITS!