



XPLORER



XPLORER OWNER'S MANUAL

Covers - Xplorer ST, Xplorer 2.0 "Shorty", Xplorer 2.2E, Xplorer 2.3F, Xplorer Toy Hauler

CONGRATULATIONS ON PURCHASING YOUR VERY OWN **HARDKORR CAMPER!**

In doing so, you now have the assurance and peace of mind that comes from purchasing a product that has been manufactured to the highest quality standards.

We hope you will enjoy using this product for many years to come.

If you require technical support, or in the unlikely event your purchase appears to be faulty, please contact our support team for immediate assistance.

- THE HARDKORR CAMPERS TEAM

IMPORTANT, RETAIN FOR FUTURE REFERENCE: READ CAREFULLY

While caution has been taken to ensure the accuracy of the contents of this guide, Hardkorr Campers assumes no responsibility for errors or omissions. Please note that specifications and product functionality may change without notice.

For assistance with assembly or installation, parts and service, visit www.hardkorrcampers.com or contact customer service through the following:



Landline: Monday - Friday
(07) 3801 8332 9AM - 4PM (AEST)



Language spoken: English
enquiries@hardkorrcampers.com

PRODUCT USAGE & MAINTENANCE

The aim of this manual is to aid owners in the proper utilization and operation of the Hardkorr Campers Xplorer 2.0 and 2.2 Camper trailer models. The content presented in this manual is directed towards individuals possessing a basic understanding of mechanical and technological concepts. If you lack the requisite skills or access to suitable tools to execute specific tasks, **we recommend seeking professional guidance.**

CONTENTS

SPECIFICATIONS	1
CAMPER TRAILER WALKTHROUGH	3
GETTING STARTED	
PRE-TRIP INSPECTION	5
WEIGHT INFORMATION	6
LOADING YOUR TRAILER	7
DRIVING TIPS	8
SETTING UP CAMP	9
TROPICAL ROOF SETUP	10
AWNING SETUP	11
HOT WATER SYSTEM SETUP	12
MAINTENANCE	13
WATER TANK ISOLATION	14
USING A JACK UNDER THE CAMPER TRAILER	15
ADJUSTING THE HANDBRAKE	16
DUST-PROOFING	17
TRAILER PLUG WIRING	18
TECHNICAL INFORMATION	19
CONTROL PANEL FUNCTIONS	20
POWER	22
HARDKORR PRODUCT MANUAL LINKS	23

	XPLORER 2.2	XPLORER 2.0 "SHORTY"
LENGTH	4.30m (from extended draw-bar to rear spare tyre/s)	
WIDTH	2.05m (including packed awning and shower ensuite fitted)	
HEIGHT	2.25m	1.98m
GROUND CLEARANCE	0.50m (to water tank)	
WHEEL TRACK	1.54m	1.64m
DEPARTURE ANGLE	25.3°	
RAMP OVER ANGLE	59°	
TARE WEIGHT	1,350kg	1,300kg
ATM	2,200kg	
GTM	2050	2100
AXLE GROUP RATING	2200	
BALL WEIGHT	80-120kg	80-100kg
TRAILER STORAGE CAPACITY	~3,900L	~3,450L
WATER	170L (100L front tank + 70L rear)	
JERRY CANS	2x 20L cans	4x 20L cans
GAS	1x standard 9kg cylinder	

TYRES	265/75 R16 MT (31.6")
LOAD RATING	123/120Q
SPEED RATING	160km/h
COLD INFLATION	550kPa
ELECTRIC BRAKE SIZE	12"
WHEEL BEARINGS	15123 cone / 15245 cup, 0.1937 x 3.375 x 0.500 standard seal, M5 x 50mm zinc split-pin

Your vehicle is required by law to be fitted with an electric brake controller. Our camper trailers are all fitted with electric brakes to comply with legislation.

12" AXLE DIAGRAM

Xplorer 2.2E / Xplorer 2.3F / Xplorer ST / Xplorer 2.0 "Shorty" / Xplorer Toy Hauler

1	BEARING CAP
2	M5 X 50MM SPLIT PIN
3	CROWN NUT
4	BEARING SEAL
5	BEARING (25580/15123)
6	HUB DRUM
7	BEARING (25580/15123)
8	BEARING SEAL
9	SPRING WASHER & NUT

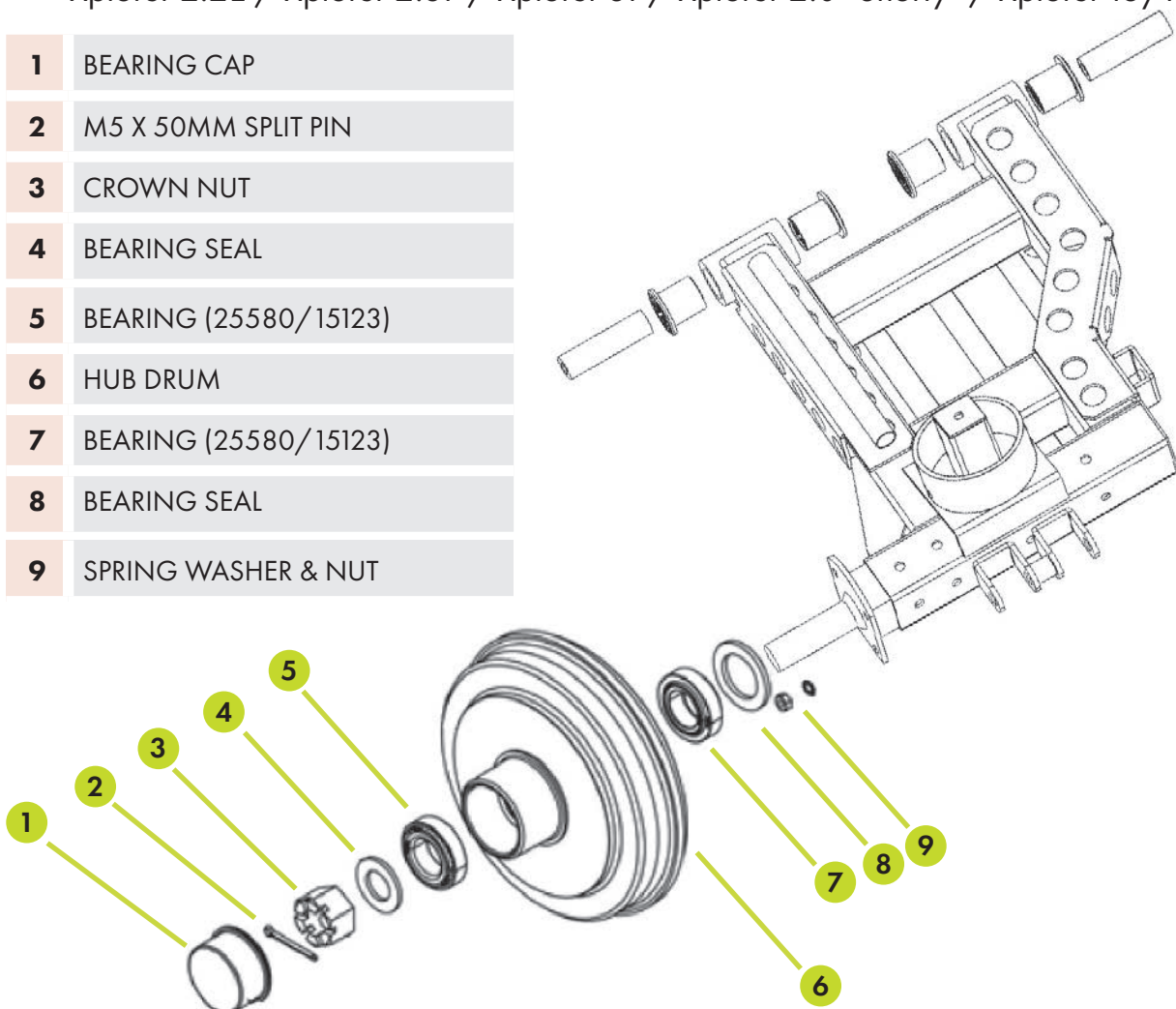

XPLORER 2.2



XPLORER 2.0 "SHORTY"



1	Hardkorr Hard Shell Dual-Fold Rooftop Tent The Dual lift system is designed to be easy and fast for one-person set up; release the latches and push the tent up, fit the two poles (included) for the tent entry cover, and you are done. Packing down is equally as easy; reverse the steps, and away you go.
2	Tent entry cover
3	Hardkorr XL 270° Free-standing Awning With a wind rating of 30 knots without leg poles, you can be sure this awning will survive our tough Australian conditions whether you're at the beach or out in the country. If the weather starts to change, we recommend securing the awning as you never know what Mother Nature is capable of.
4	Hardkorr Fold-Out Shower Tent Our Shower Tent is ideal for those looking for a bit of extra luxury while out on the road. Useful as both a shower room and as a toilet or changing space, it can be adjusted in size so that it suits the height of your trailer perfectly. The tent comes with everything you need to get it setup, as well as a removable floor with drain, and a velcro roof piece.
5	Patented integrated stairway entry to rooftop tent With the Xplorer, the game has totally changed. It's the first camper trailer in Australia to feature a staircase integrated into the trailer itself, making it much safer and less strenuous to access your tent, regardless of your age or physical condition.
6	Stairway storage compartments
7	Removable stairs
8	Gas cylinder storage
9	Stabiliser legs
10	Pull-out camp kitchen A kitchen sink, Dometic 2-burner gas stove, utensil drawer, and a large prep-bench—everything you need to cook up a storm.
11	Heavy duty independent suspension with big-bore gas shock absorbers
12	Electrical control panel
13	Pull-out 96L fridge space
14	Door-mounted dual-colour LED overhead lighting

PRE-TRIP INSPECTION - CHECK THOROUGHLY

WHEELS

- Correct tyre pressure (35-45psi)
- Tyres are in good condition
- Tread is of legal depth (1.6mm minimum)
- Wheel nuts tight (100-110ft/lb)

HITCHES & CHAINS

- Ensure hitch functions properly
- No damage to the hitch or chains
- Hitch properly lubricated
- Hitch articulates correctly

BRAKES

- Electric brakes function correctly via pedal pressure inside the vehicle
- Breakaway wire connected

TRAILER LIGHTS

- Indicators function properly
- Front marker lamps function properly (turn headlights on)

ELECTRICAL

- Batteries are full and in good condition (Lithium 14v | AGM 13.2v)
- You can see via the monitor your DC-DC is charging your batteries, check solar and vehicle individually.
- Fridge turns on and stays cool (make sure to put some items inside)

UNDER TRAILER

- On each bolt, nut or fitting there will be a paint pen mark, we do this as a precautionary so you can quickly check if anything has come loose in your travels.
- Bearings should be checked prior to departure.
- There are 4x Grease nipples on the control arms, depending on the age or kms of the trailer this should be checked also.

MISCELLANEOUS

- Keys for the trailer doors.
- Tools
- Jack (not supplied by HKC)
- Spare wheel is inflated

WEIGHT INFORMATION

Towing your camper trailer safely under varying conditions can present challenges. Properly loading your camping trailer in a safe and suitable manner can help reduce the risk of potential hazards during your journey. While there may be numerous abbreviations and terms that initially seem confusing, understanding them will ultimately enhance your towing experience.

BALL WEIGHT

This is the downward load exerted on the towing point of your vehicle by the trailer. A general rule of thumb is the ball weight should be close to 10% of the trailers ATM.

TARE WEIGHT

Tare Weight is the total weight of the trailer with all the options fitted by Hardkorr Campers with no liquids or fluids not essential to the operation of the Xplorer camper trailer.

GTM

The gross trailer mass (GTM) is the maximum amount of weight that can be supported by the suspension minus the ball weight.

ATM

The aggregate trailer mass (ATM) is the maximum amount of weight that can be supported by the trailer and **must not be exceeded**.

The Xplorer 2.2 has a **Tare Weight** of **1350kg**, and the **ATM** is **2200kg**. This means you can load approximately 850Kg. Once your 170L of water storage is filled up your allowable weight will now be 680Kg.

You may have also heard about GCM (Gross Combined Mass). This is the maximum allowed mass of the vehicle and trailer as determined by the vehicle manufacturer.

LOADING YOUR TRAILER

To ensure the trailer can be towed safely and effectively, it is recommended to follow the below diagram when packing your Xplorer camper trailer. Adhering to the appropriate weight distribution is crucial to a smooth, safe towing experience.



LIGHTWEIGHT ITEMS

- Clothing
- Food
- Recreational items

MID-WEIGHT ITEMS

- Aluminium frame camp chairs
- Cooking utensils/pots/pans

HEAVY ITEMS

- Trestle table
- Steel frame camp chairs

DANGER

Exceeding manufacturer weight and combination limits can result in loss of control leading to death or serious injury. Your tow vehicle and hitch must be rated for the Gross Vehicle Weight of the trailer.

OFF-ROAD DRIVING

When towing your camper off-road, it introduces a plethora of additional responsibilities and considerations for the driver. When journeying into remote areas, it's imperative to be equipped with an ample supply of spare parts and provisions to handle any unforeseen circumstances effectively.

Prioritise regular preventative maintenance and conduct thorough **daily inspections** without fail.

Essential trailer spare parts should include:

- Wheel bearings (*see page 2*)
- Seals
- Wheel studs and nuts

CORRUGATIONS AND ROUGH ROADS

Corrugated roads pose one of the most challenging and detrimental conditions for vehicles. The continuous vibration experienced can gradually loosen vehicle components, significantly stressing both vehicles and drivers beyond the usual strains of regular road driving. It is essential to take frequent breaks in such conditions to alleviate driver fatigue and prevent excessive wear on vehicles.

The intense heat generated on corrugated roads can pose a risk to shock absorbers, potentially damaging seals and leading to shock absorber fade, where damping effectiveness decreases, and in severe cases, seal failure. To mitigate these risks, it is crucial to adjust tire pressures on both the car and trailer, softening the impact and expanding the tire's contact area with the road surface, particularly on rough and corrugated terrain.

BULLDUST

This occurrence is frequently encountered on outback roads, where fine dust can accumulate in sizable potholes, concealing them from drivers who may not anticipate their presence. It is crucial to decrease speed in such conditions and exercise caution while driving to minimize the risk of damage or accidents. Remember to check and clean vent filters as needed.

SAND

When navigating sandy terrain, it's essential to adjust the tyre pressures on both the vehicle and trailer. This adjustment increases the tyre's footprint, minimising the depth of sinking into the sand.

Always bear in mind that lower tire pressure necessitates lower driving speeds. When reducing pressures to 20 psi or below, there's an increased risk of the tire's bead rolling off the rim, particularly during sharp turns.

CHOOSING A SPOT

There's no such thing as a perfectly flat piece of ground out in the bush, but your camper has stabiliser legs which can help with this. Choose a spot that doesn't have overhanging tree branches where birds and bats nest. Bat poo, especially, can be quite harsh on paint surfaces!

It's also worth noting that Gumtrees, in particular, have a bad history of shedding branches and damaging cars. Be wary of this!

LEVELLING THE CAMPER

On your camper is 4 stabiliser legs, please note these are for stabilising the camper and not raising it. The best way of levelling your camper is to bring some levelling blocks, pieces of timber or anything you can drive the camper onto.

SITE POWER (OPTIONAL)

On the back of the Xplorer will be a black 240V 15A inlet. Using a 15A power lead connected to mains power, insert it into the inlet. From here, the power flows to an RCD before reaching an outlet.

SECURING YOUR CAMPER TRAILER

Something unfortunately not a lot of people consider is bringing a hitch lock and/or a wheel clamp. We recommend having these accessories so you don't have to worry about leaving your camper behind at the site when going on a day trip!

THE EASIEST SETUP YOU'LL EVER PERFORM

Scan the QR Code to have a fast but informative set up video.



TROPICAL ROOF SETUP

In the camper will be a black bag which contains;

- 2x pieces of canvas
- A pole
- Rope and ground pegs

SET UP

1. Ensure camper is still packed up; awning included.
2. At the front and passenger side of your Xplorer Double lift tent is a sail track. With the tent still collapsed, slide in both pieces of canvas into the sail track.
3. Before lifting the tent there is a piece of velcro which you will use to join the two pieces together, on the eyelets of the canvas you will need to attach the bungee cords / ropes.
4. Lift up the tent
5. With the tent now set up and canvas draping over the camper, you can now set up the awning.
6. With the awning now set up, tie off one side of the canvas to the arm of the awning. The other side of the canvas you will need to set up with a pole, rope and ground peg.
7. The piece of canvas that goes over the awning covering you will need to attach to the awning arms via the ropes you installed on step 3.

All done! Make adjustments where needed but that's all you have to do.



AWNING WALL SETUP

Depending on which walls you have, you will need the following;

- Awning wall
- Ground pegs
- Hammer
- Awning pole

SET UP

1. Install a pole to each awning arm where to help support the weight of the canvas as it hangs.
2. With the awning fully setup, attach it the awning wall to the awning edge using the velcro strips at the top of the awning walls.
3. Pull the awning wall out at an angle and secure it to the ground using ground pegs. You may need your hammer for this.

All done! Make adjustments where needed, but that's all you have to do.



Keeping the Velcro clean will ensure its longevity.



HOT WATER SYSTEM SETUP

- If you have purchased a hot water system with your Xplorer the unit will have come with premade hoses. In this kit there will be;
- Freestanding tripod
- Water T-Piece
- Green garden hose with hydraulic fitting
- Braided hose with hydraulic fitting
- Gas connector
- Batteries

SET UP

1. Set up the free-standing tripod, and then hang the hot water system on the stand
2. On the bottom of the hot water system there is two inlets and one outlet. Left side is **Gas IN**, Middle is **Water Out** and the Right side is **Water IN**. Using the provided gas bayonet lead, connect the gas lead to the left side of the unit, and connect the other side of the gas hose into one of the bayonet fittings near your gas bottle.
3. With the green garden hose, connect the hydraulic fitting into the driver's side water fitting on the draw bar, and the other side of the garden hose to the **Water IN** connection on the hot water unit.
4. All you need to do now is connect the water outlet. We have designed this in a way where you can have water to the kitchen sink and to the shower head at the same time.
5. Connect the T-Piece to the unit. On one side of the T-Piece, connect the braided hose with hydraulic fitting to the passenger side draw bar, exactly the same way you did with the green garden hose. On the last outlet of the T-Piece, connect your shower head via a hose to the T-piece.
6. Install the supplied batteries.
7. Turn the water pump on in the camper.
8. Turn the gas bottle valve open.
9. Turn on the hot water system.

For further information or troubleshooting advice, please contact Country Comfort.

CANVAS

When packing up your tent and awning, it is important to ensure it is clean and dry when doing so. Mould is exceptionally hard to remove from canvas once it has set in, a couple of minutes in the sun or some time with a towel / dry rag goes a long way.

If you encounter a leak in the canvas use **Seam Sealer** to fix the issue.

ZIPPERS (TENT/AWNING)

Never force a zipper - if it jams or binds up, pull it back a few inches and try again. We recommend keeping a can of **dry lubricant** handy in case the zippers become an issue.

CAMPER EXTERIOR

Just like your car, your camper should be taken care of just the same. The exterior is a hammer-tone electric plated finish so you don't have to be as careful with it, but for longevity basic soap wash and occasional buff/wax will keep your camper in great condition.

CAMPER INTERIOR

High humidity environments like North Queensland and cooler climates can create condensation, add some heat to that and you have the perfect environment for mould. For a few dollars at any grocery store, a moisture absorber stored in the tent and body of the camper will ensure no nasty surprises when you take your camper back out on your next holiday. If you are in a cold climate, open the top of the window zippers slightly to stop the condensation from your breath from being trapped inside the tent, if you don't open up some zips, in the morning you will notice moisture inside your tent roof and walls. A fan running through the night will also help prevent moisture in the tent.

CAMPER UNDER-BODY

No doubt at some stage you will want to do a beach camping trip! Even though the body of the camper is aluminium and chassis has been hot dip galvanised ensuring rust proofing, salt has a way of finding any nook or cranny that is unprotected. A couple of minutes spent with a spray can of **lanolin** works wonders, we recommend doing this before and after your trip!

BATTERIES

In contrast to standard batteries, lithium batteries benefit from being discharged as much as possible when stored for extended periods. Doing so can help maintain the condition of your batteries over time. At the conclusion of a trip, consider leaving some lights on in the camper to gradually discharge the battery to around 40% or 13 volts.

ISOLATING WATER TANKS

Under the body of your camper trailer you have two water tanks. The front water tank is 100L and the rear is 70L. In the first door on the drivers side of the trailer, on the opposite side of where your breaker switches are, there are two isolation valves.



The valve on the left, which is closest to the door, is the isolator for the front tank. The valve at the back is the isolator for the back tank.

If the valve is like the photo above, the valve is open. If the valve is like the photo on the right, the valve is in its closed position.

We recommend draining the two tanks together rather than individually. If the water pump starts to make noise once pressure is built or the water is extremely aerated one of the tanks may be empty.



USING A JACK UNDER THE CAMPER TRAILER

The Xplorer has no specific jacking point, but the best jacking point is under the control arm by the shock absorbers. The best and safest method for jacking the camper is as follows

1. Using an appropriate sized jack, raise the trailer up by the control arm near the shock absorbers.
2. When jacking the camper up, have the camper trailer's stabiliser legs being adjusted as you do this to touch the ground. This is not necessary but safety is paramount.
3. Once the camper is at your desired height, before going under the camper please ensure you have adequate safety measures in place, the weight of the camper being supported by the jack, stabiliser legs or both at the same time is not adequate.
4. Where possible depending on the circumstances, be sure to place a wheel, large rock or tree stump under the trailer while its jacked up, or if possible have jack stands on various points of the trailer chassis.



RECOMMENDED JACKING POINT

ADJUSTING THE HANDBRAKE

Naturally as your camper ages your handbrake is going to require adjusting. Loosen off the two 17mm nuts and close the gap between them by rotating the round disc on the bolt, pull the handbrake and check for tension. Once happy tighten the nuts back up.

Please note that you do not want this too tight. If done up too tight you may cause unnecessary wear to the brake pads.

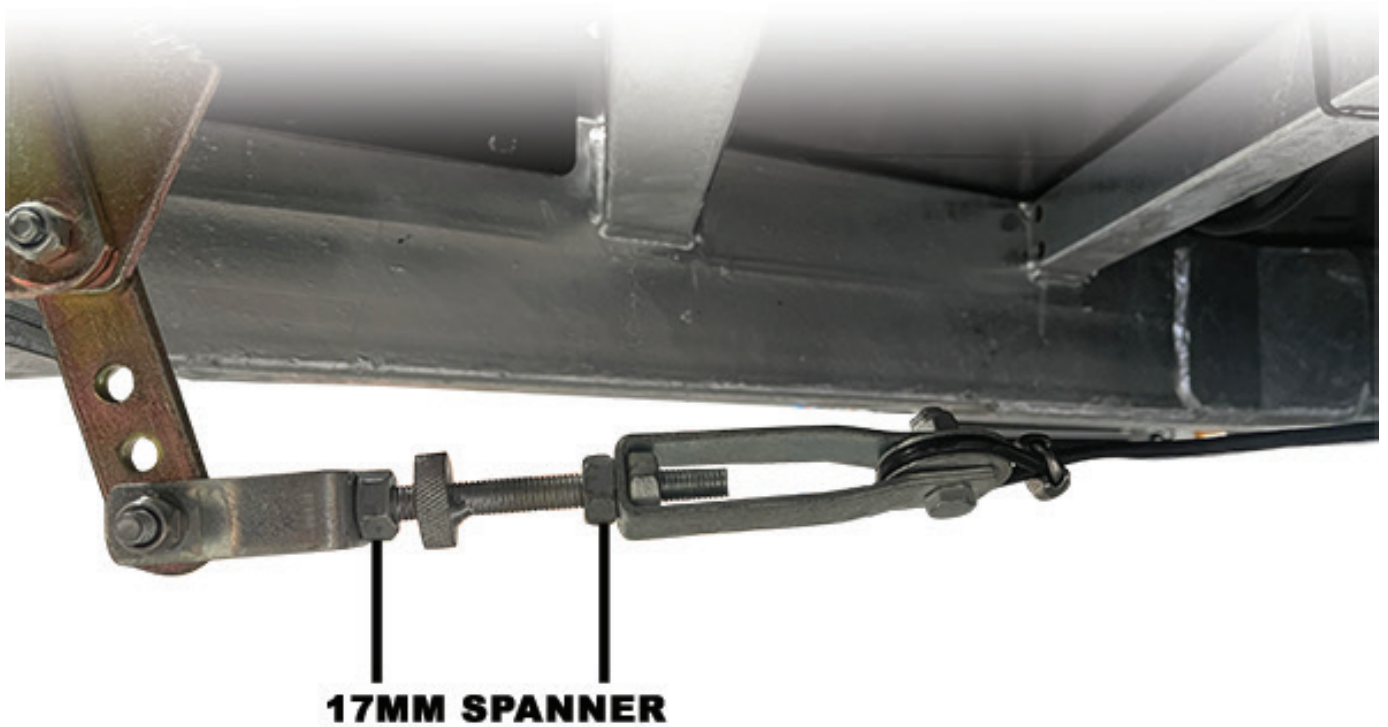

DUST-PROOFING THE CAMPER TRAILER

On each door of the Xplorer there are three door locks which are all adjustable. Using a 10mm spanner, loosen the locking nut. By winding the bolt outwards, this will increase the clamping force of the lock against the body of the trailer which will result in the door rubbers being squished more. There is no set limit as this will be done by feel. Please note leaving the door rubbers set for the entirety of the campers life will reduce the effectiveness of these rubbers, in storage it is best to loosen off the bolts to keep the rubbers plush.



Door Lock



10mm spanner on locking nut



Bolt wound all the way out for maximum pressure

TRAILER PLUG WIRING

The below pin-out diagram can be used to diagnose any faulty connections if one or more lights in the camper trailer are not functioning.

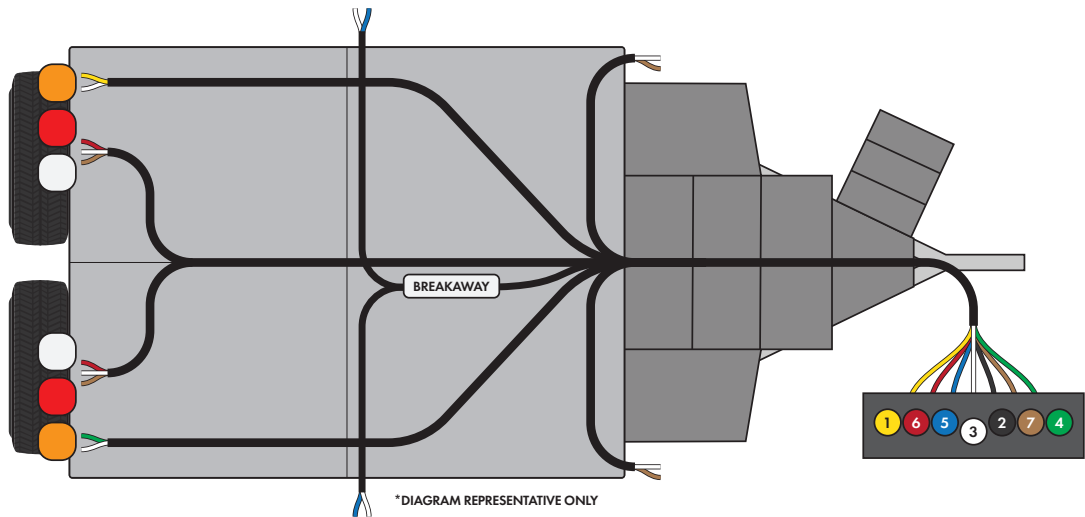

Male plug



1	LEFT indicator	5	Service brakes
2	Reverse lights (not used by HKC)	6	Brake lights
3	Earth	7	Tail lights, side markers, clearance lights
4	RIGHT indicator		

Please note: All lights have been tested before delivery of your camper trailer.

CONNECTION TERMINOLOGY



FEMALE WATER CONNECTOR

1/4" ISO-B Hydraulic hose
quick coupler plug.
(stainless steel - ISO 7241-1 B)



MALE WATER CONNECTOR

1/4" ISO-B Hydraulic hose
quick coupler plug.
(stainless steel - ISO 7241-1 B)



GAS CONNECTION

1/2" MBSP bayonet fitting.



7-PIN FLAT CAR CONNECTOR

Male 7-pin flat connector for
trailers/caravans.



3-PIN ANDERSON PLUG

3-Pin 50A Anderson-style plug for
DC-DC charging.



SOLAR PANEL INPUT

WS20 2-pin electrical aviation
connector (female).



240V 15A MAINS INPUT

15A plug connection found
at caravan parks or powered
campsites.

CONTROL PANEL FUNCTIONS



WATCH OUR
VIDEO TUTORIAL



YouTube

1	Hardkorr Battery Monitor	5	80A circuit breaker
2	USB 2.0, 2x 12V lighter sockets	6	Water meter
3	Water pump switch, lighting switches, fan switch	7	Main power isolator
4	Reset switches	8	Solar + spare wirable switch

1. The battery monitor will show you everything you need to know regarding the status of your battery. It will display how many amps you have left, how long you can last until you're dead flat, and will show you the charging and discharge status in real-time. If you have an inverter, you can also use the display to gauge how many watts you are drawing. For more information, scan the QR Code on page 23.
2. On top are 2x USB ports that you can use to charge electronic devices such as phones or tablets. They will have a built-in blue light. When power is supplied, this blue light will turn on. Beneath the USB ports are 2x lighter sockets that you can use for 12V accessories.
3. By pressing the Water Pump Switch, it will turn the pump on. The pump will automatically stop drawing power once it builds pressure. It is highly recommended that you do not travel or leave the trailer unattended with the pump switch turned on.

You will know the switch is on via the blue LED ring around it. The Kitchen Light Switch simply allows power to flow through to the mini control panel on the pull-out kitchen.

The Light Switch simply allows power to flow through to the lights on each door of the camper. This does not turn your lights on and off. If your lights do not turn on by pressing this switch, you have to manually turn your lights on via the dimmer switch near the light located on the door.

4. These are reset switches, if you ever find there is a fault with the water pump or the fan does not work, try pressing these reset switches.
5. This is the main circuit breaker for all the accessories the control panel features.
6. On the left is your 100L water meter. On the right is your 70L water meter.
7. This is essentially your on and off switch for the control panel.
8. For camper trailers not fitted with a DC-DC, you will need to turn the top switch on to allow solar power to flow through to the solar regulator, for trailers fitted with a DC-DC, this is effectively a dead switch that does nothing because the DC-DC is automatic. The bottom switch labeled as "OTHER" will turn on the white area lights in the rear bar of the camper located next to the indicators, please note this is NOT a reverse light.

WATER PUMP

In our campers, we use Shurflo pressure-lock water pumps. Simply press the water pump button on the control panel to activate it. If your taps are already in the off position, no action occurs as pressure has already been built up. However, as soon as you turn on a tap, the pump initiates the flow of water. It's strongly advised to switch the button to the off position when you're away from the trailer for safety.

FAN SWITCH

We've affixed a 12v electric fan to the camper door adjacent to the kitchen, designed primarily to ward off dust infiltration into the trailer. While you might not find much use for it during highway or beach trips, it's especially handy for traversing central Queensland's bulldust-like roads. Activating the fan before setting off pressurizes the camper's interior, aiding in dust prevention throughout your journey.

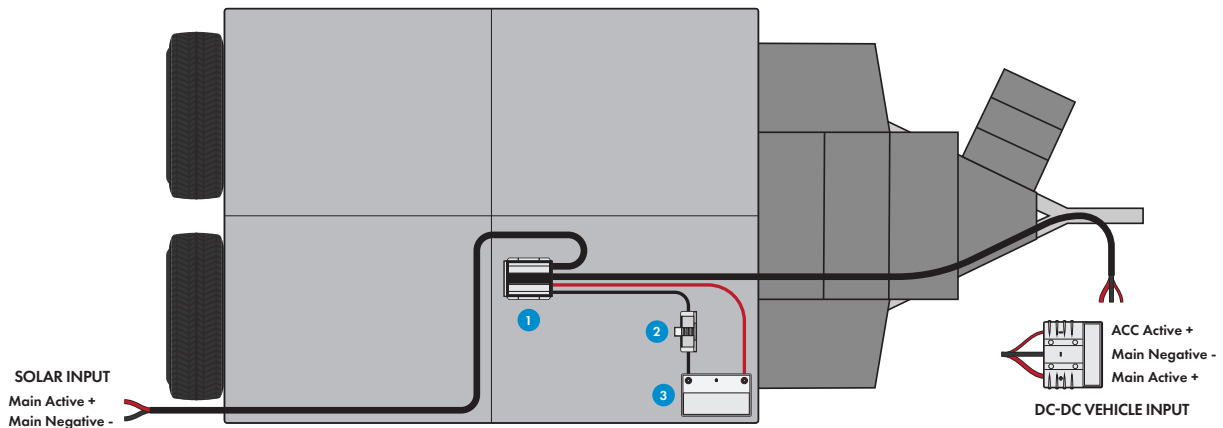

1 DC-DC CHARGER

Serves as both a charging point for the battery via the vehicle's alternator, as well as a regulator for the solar-generated power.

2 SHUNT

Used to measure power coming into and out of the trailer battery system.

3 BATTERY

Power your 12V electrical devices with the power from the battery.

SOLAR INPUT BREAKER: 40A

3 PIN ANDERSON BREAKER: 50A

DCDC OUTPUT BREAKER: 50A

USING 240V MAINS POWER

Please connect the 15A power lead to the rear of the trailer through the inlet. The power will pass through a 15A RCBO circuit protector, subsequently branching out to a dual 240V outlet.

From there, it will proceed to a robust 25A battery charger, automatically linking to your batteries. Upon powering on, your batteries will commence charging provided the camper trailer is connected to a power source. If, however, your appliances remain unpowered, the initial step is to inspect the RCBO and ensure that the breaker hasn't tripped.

USING THE DC-DC CHARGER

The DC-DC unit installed in your camper serves two primary functions: solar and vehicle charging. What's even more convenient is its automatic feature, which selects between solar and vehicle charging based on the power output. For instance, if you're driving and your solar input is at +10A while your vehicle input is at +15A, the system will prioritize the vehicle input over solar. However, it's important to note that the unit will not combine both inputs to reach a total of +25A.

3-PIN ANDERSON-STYLE PLUG WIRING

You will require a 3-pin Anderson to use with your DC-DC Charger. We use a 3-Pin so when you turn your car off, the DC-DC knows to turn off and not drain the battery flat in your vehicle.

HARDKORR

We only use Hardkorr branded batteries, solar panels, chargers etc. As technology progresses we are always updating the products we use in our campers. If you cannot find the manual of your charger or battery please visit the Hardkorr website at www.hardkorr.com/au

40A DC-DC CHARGER

We use the Hardkorr DC-DC charger which controls 2 charging functions. Solar and Vehicle. When driving along, your car will be charging your batteries in the trailer or when you're parked up, charging from your solar panels.



BATTERY MONITOR

This battery monitor displays essential information such as battery voltage, live current draw (A) and charge level (Ah and %) through its full-colour LCD screen or by connecting your smartphone via Bluetooth. A=Amps | Ah= Amp Hours



2000W INVERTER

Bring the convenience of your favourite appliances from home with you whether you're touring the country, on a weekend away, or on the job site. Capable of charging your everyday devices or powering appliances like your coffee machine or induction cooktop, our 2000W inverter is perfect for those wanting to work or live out of their 4x4, caravan, or camper trailer.



135AH LITHIUM BATTERY

Our latest range of 135Ah lithium (LiFePO₄) deep-cycle batteries are the most reliable, technologically-advanced batteries we have ever manufactured. With Bluetooth® monitoring, outstanding performance characteristics, full international certification and 135Ah of usable power into a standard Group 27 (N70) size case, you'll never be caught short of 12v power again!



25A BATTERY CHARGER

Charge your batteries from AC/mains power with our 240V Battery Chargers. Equipped with an automatic 9-stage charging system, our chargers are designed to quickly get your batteries up to health. The charger can be used with 12V SLA, AGM, calcium, and LiFePO₄ batteries.



170W SOLAR PANEL

Our high-quality 170w fixed solar panels will fit neatly on the roof of a 4wd, caravan, camper trailer or boat. Being only 17mm high, they are aerodynamic and weigh about 30% less than regular 30mm high fixed panels.



HOW TO VIDEO
PLAYLIST



LIFE
WITHOUT
LIMITS!